

HYDRAULIC PUMPS TEST STAND TBP12

液压油泵测试机 TBP12

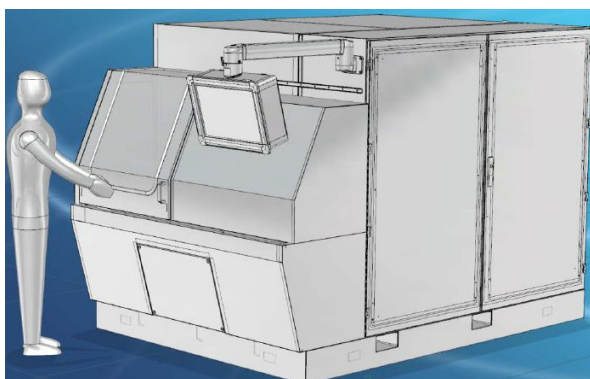

TBP12 is a production test stand for running in and testing of hydraulic single gear pumps. The test stand can test pumps with flow rate up to 70 lt/min (18.5 gpm) and pressure up to 320 bar (4641.2 psi) considering the power of the electric motor of 30 kW.

TBP12是一台生产测试机，用来测试运行中的测试液压单齿轮泵。本机可测试流量高达70 lt/min (18.5 gpm) · 和压力达320 bar (4641.2 psi) · 30 kW电动机的动力泵。

Technical Features/技术信息

Safety Devices / 安全装置	<ul style="list-style-type: none"> - Emergency push button/紧急按钮 - Test area sheltered with a sliding door of lexan panels/热塑聚碳酸酯板制成的滑动门保护测试区 - Oil recovery vessel/回收油容器
Power Supply / 电源供应	<ul style="list-style-type: none"> - electric standard supply/标准 : 400 VAC - 50 Hz - 40 kW - compressed air/压缩空气 : 5÷6 bar (72 ÷ 87 psi) - industrial cooling water/工作循环冷却水: T≤ 68°F
Dimensions / 尺寸	2000 x 2900 x 2000 mm (79" x 114" x 79")
Max flow/最大流量	70 lt/min (18.5 gpm)
Reservoir / 蓄水	250 lt (66 gallons)
Max pressure / 最大压力	320 bar (4641.2 psi)
Instrumentation / 仪器	<ul style="list-style-type: none"> - Gear flow meter/齿轮流量计 (acc. +/-0.3% r.v.) - Pressure transducer/压力传感器 (acc. +/-0,25% f.s.) - Temperature meter/温度仪表 PT100 cl. A - Optional torque meter/可选扭力表 (acc. +/-0,01% f.s.)
Other/其它	<p>The test stand can operate with hydraulic industrial oils such as ISO VG 32 and ISO VG 46. The test stand needs about 300 (~ 79 gallons) liters of oil at the first start up.</p> <p>本机支持如ISO VG32 和VG46之类液压工业油，初次启动需约300 (~ 79 gallons)油量</p>

*Technical specifications can be changed without notice/技术规格可不事先通知而变动

*The details or other specifications, please contact us! / 详细细节或其它规格机器，请洽我司!

